

## Data Sheet

# 10Gb CWDM XFP Transceiver, 80km Hot Pluggable, Duplex LC, CWDM EML-LD, APD Receiver, SM PXF-1C71SF-XX

Issue: November 2010



### Features:

- Support multi protocol from 9.9Gb/s to 10.5Gb/s
- Hot pluggable 30 pin connector
- Compliant with XFP MSA
- Transmission distance of 80km over single mode fiber
- CWDM EML laser transmitter.
- Duplex LC connector
- APD Receiver
- 2-wire interface for management and diagnostic monitor
- XFI electrical interface with AC coupling
- Power supply voltages : +3.3V, +5V
- Temperature range -5°C to 70°C
- Power dissipation: <3.5W
- RoHS Compliant Part



### Applications:

- 10GBASE-ZR Ethernet
- 80km 10G FC
- Other optical links

### Description:

PeakOptical's PXF-1C71SF-XX Small Form Factor 10Gb/s (XFP) transceivers are compliant with the current XFP Multi-Source Agreement (MSA) Specification. The high performance cooled CWDM EML transmitter and high sensitivity APD receiver provide superior performance for SONET/SDH and Ethernet applications up to 40km optical links.

### Specification:

#### Electrical Characteristics (Condition: $T_a = T_{OP}$ )

Parameter	Symbol	Min	Typ	Max	Unit	Note
Main Supply Voltage	Vcc5	4.75		5.25	V	
Supply Voltage #2	Vcc3	3.13		3.45	V	
Supply Current – Vcc5 supply	Icc5			250	mA	
Supply Current – Vcc3 supply	Icc3			500	mA	
Module total power	P			3.5	W	
<b>Transmitter</b>						
Input differential impedance	Rin		100		$\Omega$	1
Differential data input swing	Vin,pp	150		1000	mV	
Transmit Disable Voltage	VD	2.0		Vcc	V	

All rights reserved, including intellectual property rights. Technical data subject to modifications and delivery subject to availability. Any liability that the data and illustrations are complete, actual or correct is excluded. Designations may be trademarks and/or copyrights of the respective manufacturer, the use of which by third parties for their own purposes may infringe the rights of such owner.

## Data Sheet

# 10Gb CWDM XFP Transceiver, 80km Hot Pluggable, Duplex LC, CWDM EML-LD, APD Receiver, SM PXFP-1C71SF-XX

Issue: November 2010



Transmit Enable Voltage	VEN	GND		GND+ 0.8	V		
Transmit Disable Assert Time	T_off			10	us		
Tx Enable Assert Time	T_on			2	ms		
<b>Receiver</b>							
Differential data output swing	Vout,pp	300	600	750	mV		
Data output rise time	tr			45	ps	2	
Data output fall time	tf			45	ps	2	
LOS Fault	VLOS fault	Vcc - 0.5		VccHOST	V	3	
LOS Normal	VLOS norm	GND		GND+0.5	V	3	
Power Supply Rejection	PSR	See Note 4 below					4

1. After internal AC coupling.
2. 20 – 80 %
3. Loss Of Signal is open collector to be pulled up with a 4.7k – 10kohm resistor to 3.15 – 3.6V. Logic 0 indicates normal operation; logic 1 indicates no signal detected.
4. Per Section 2.7.1. in the XFP MSA Specification.

### Optical Characteristics (Condition: $T_a = T_{op}$ )

Parameter	Symbol	Min	Typ	Max	Unit	Ref.	
<b>Transmitter</b>							
Operating Date Rate	B	9.9		10.5	Gb/s		
Bit Error Rate	BER			$10^{-12}$			
Optical Modulation Amplitude (OMA)	POMA	-2.1		-	dBm	1	
Maximum Launch Power	PMAX	-1		+4	dBm	1	
Optical Wavelength	$\lambda$	$\lambda-5.5$		$\lambda+7.5$	nm		
Optical Extinction Ratio	ER	6			dB		
Spectral Width	$\Delta\lambda$			1	nm		
Sidemode Supression ratio	SSRmin	30			dB		
Rise/Fall Time (20%~80%)	Tr/Tf			50	ps		
Average Launch power of OFF Transmitter	POFF			-30	dBm		
Tx Jitter	Txj	Compliant with each standard requirements					
Optical Eye Mask		IEEE802.3ae					2
<b>Receiver</b>							
Operating Date Rate	B	9.9		10.5	Gb/s		
Receiver Sensitivity	R			-24	dBm	2	
Maximum Input Power	PMAX			-9	dBm	2	
Optical Center Wavelength	$\lambda_C$	1260		1600	nm		
Receiver Reflectance	Rrx			-27	dB		
LOS De-Assert	LOSD			-25	dBm		

All rights reserved, including intellectual property rights. Technical data subject to modifications and delivery subject to availability. Any liability that the data and illustrations are complete, actual or correct is excluded. Designations may be trademarks and/or copyrights of the respective manufacturer, the use of which by third parties for their own purposes may infringe the rights of such owner.

# Data Sheet

## 10Gb CWDM XFP Transceiver, 80km Hot Pluggable, Duplex LC, CWDM EML-LD, APD Receiver, SM PXFP-1C71SF-XX

Issue: November 2010



LOS Assert	LOSA	-35			dBm	
LOS Hysteresis	-	-	2	5	dB	

### Notes:

1. The optical power is launched into SMF.
2. Measured with a PRBS  $2^{-31}-1$  test pattern @10.3125Gbps BER< $10^{-12}$ .

### Absolute Maximum Ratings

Parameter	Symbol	Min	Max	Unit
Storage Temperature	T <sub>ST</sub>	-40	+85	°C
Operating Temperature	T <sub>IP</sub>	-5	+70	°C
Supply Voltage 1	V <sub>CC3</sub>	-0.5	+4.0	V
Supply Voltage 1	V <sub>CC5</sub>	-0.5	+6.0	V

### Recommend Operation Environment:

Parameter	Symbol	Min	Typ	Max	Unit
Supply Voltage 1	V <sub>CC</sub>	+3.1	3.3	+3.5	V
Supply Voltage 1	V <sub>CC</sub>	+4.75	5.0	+5.25	V
Operating Temperature	T <sub>OP</sub>	-5	-	+70	°C

### Pin Assignment:

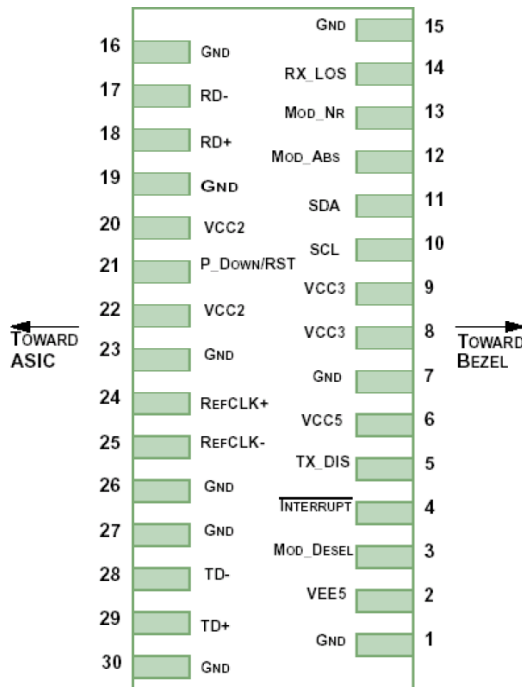

**Diagram of Host Board Connector Block Pin Numbers and Name**

All rights reserved, including intellectual property rights. Technical data subject to modifications and delivery subject to availability. Any liability that the data and illustrations are complete, actual or correct is excluded. Designations may be trademarks and/or copyrights of the respective manufacturer, the use of which by third parties for their own purposes may infringe the rights of such owner.

## Data Sheet

# 10Gb CWDM XFP Transceiver, 80km Hot Pluggable, Duplex LC, CWDM EML-LD, APD Receiver, SM PXF-1C71SF-XX

Issue: November 2010



### Pin Description:

Pin	Logic	Symbol	Name/Description	Ref.
1		GND	Module Ground	1
2		VEE5	Optional -5.2 Power Supply - Not required	
3	LVTTL-I	Mod-Desel	Module De-select; When held low allows the module to respond to 2-wire serial interface commands	
4	LVTTL-O	Interrupt	Interrupt (bar); Indicates presence of an important condition which can be read over the serial 2-wire interface	2
5	LVTTL-I	TX_DIS	Transmitter Disable; Transmitter laser source turned off	
6		VCC5	+5 Power Supply	
7		GND	Module Ground	1
8		VCC3	+3.3V Power Supply	
9		VCC3	+3.3V Power Supply	
10	LVTTL-I	SCL	Serial 2-wire interface clock	2
11	LVTTL-I/O	SDA	Serial 2-wire interface data line	2
12	LVTTL-O	Mod_Abs	Module Absent; Indicates module is not present. Grounded in the module.	2
13	LVTTL-O	Mod_NR	Module Not Ready;	2
14	LVTTL-O	RX_LOS	Receiver Loss of Signal indicator	2
15		GND	Module Ground	1
16		GND	Module Ground	1
17	CML-O	RD-	Receiver inverted data output	
18	CML-O	RD+	Receiver non-inverted data output	
19		GND	Module Ground	1
20		VCC2	+1.8V Power Supply - Not required	
21	LVTTL-I	P_Down/RS T	Power Down; When high, places the module in the low power stand-by mode and on the falling edge of P_Down initiates a module reset Reset; The falling edge initiates a complete reset of the module including the 2-wire serial interface, equivalent to a power cycle.	
22		VCC2	+1.8V Power Supply - Not required	
23		GND	Module Ground	1
24	PECL-I	RefCLK+	Reference Clock non-inverted input, AC coupled on the host board - Not required	3
25	PECL-I	RefCLK-	Reference Clock inverted input, AC coupled on the host board - Not required	3
26		GND	Module Ground	1
27		GND	Module Ground	1
28	CML-I	TD-	Transmitter inverted data input	
29	CML-I	TD+	Transmitter non-inverted data input	
30		GND	Module Ground	1

All rights reserved, including intellectual property rights. Technical data subject to modifications and delivery subject to availability. Any liability that the data and illustrations are complete, actual or correct is excluded. Designations may be trademarks and/or copyrights of the respective manufacturer, the use of which by third parties for their own purposes may infringe the rights of such owner.

## Data Sheet

### **10Gb CWDM XFP Transceiver, 80km Hot Pluggable, Duplex LC, CWDM EML-LD, APD Receiver, SM PXF-1C71SF-XX**

Issue: November 2010



#### Note

1. Module circuit ground is isolated from module chassis ground within the module.
2. Open collector; should be pulled up with 4.7k – 10k ohms on host board to a voltage between 3.15V and 3.6V.
3. A Reference Clock input is not required.

#### **Digital Diagnostic Functions:**

As defined by the XFP MSA 1, PeakOptical's XFP transceivers provide digital diagnostic functions via a 2-wire serial interface, which allows real-time access to the following operating parameters:

- ✓ Transceiver temperature
- ✓ Laser bias current
- ✓ Transmitted optical power
- ✓ Received optical power
- ✓ Transceiver supply voltage

It also provides a sophisticated system of alarm and warning flags, which may be used to alert end-users when particular operating parameters are outside of a factory-set normal range.

The operating and diagnostics information is monitored and reported by a Digital Diagnostics Transceiver Controller (DDTC) inside the transceiver, which is accessed through the 2-wire serial interface. When the serial protocol is activated, the serial clock signal (SCL pin) is generated by the host. The positive edge clocks data into the XFP transceiver into those segments of its memory map that are not write-protected. The negative edge clocks data from the XFP transceiver. The serial data signal (SDA pin) is bi-directional for serial data transfer. The host uses SDA in conjunction with SCL to mark the start and end of serial protocol activation. The memories are organized as a series of 8-bit data words that can be addressed individually or sequentially. The 2-wire serial interface provides sequential or random access to the 8 bit parameters, addressed from 000h to the maximum address of the memory.

For more detailed information including memory map definitions, please see the XFP MSA Specification.

# Data Sheet

## 10Gb CWDM XFP Transceiver, 80km Hot Pluggable, Duplex LC, CWDM EML-LD, APD Receiver, SM PXFP-1C71SF-XX

Issue: November 2010

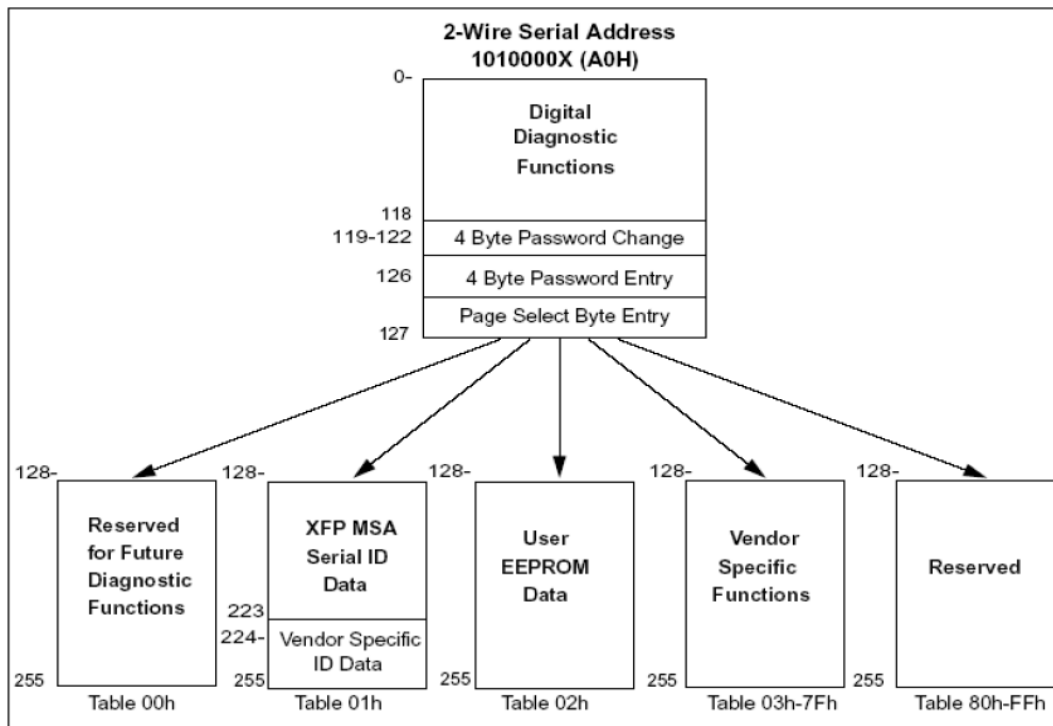

All rights reserved, including intellectual property rights. Technical data subject to modifications and delivery subject to availability. Any liability that the data and illustrations are complete, actual or correct is excluded. Designations may be trademarks and/or copyrights of the respective manufacturer, the use of which by third parties for their own purposes may infringe the rights of such owner.

**10Gb CWDM XFP Transceiver, 80km**  
**Hot Pluggable, Duplex LC, CWDM EML-LD, APD Receiver, SM**  
**PXFP-1C71SF-XX**

Issue: November 2010



**Recommended Circuit:**

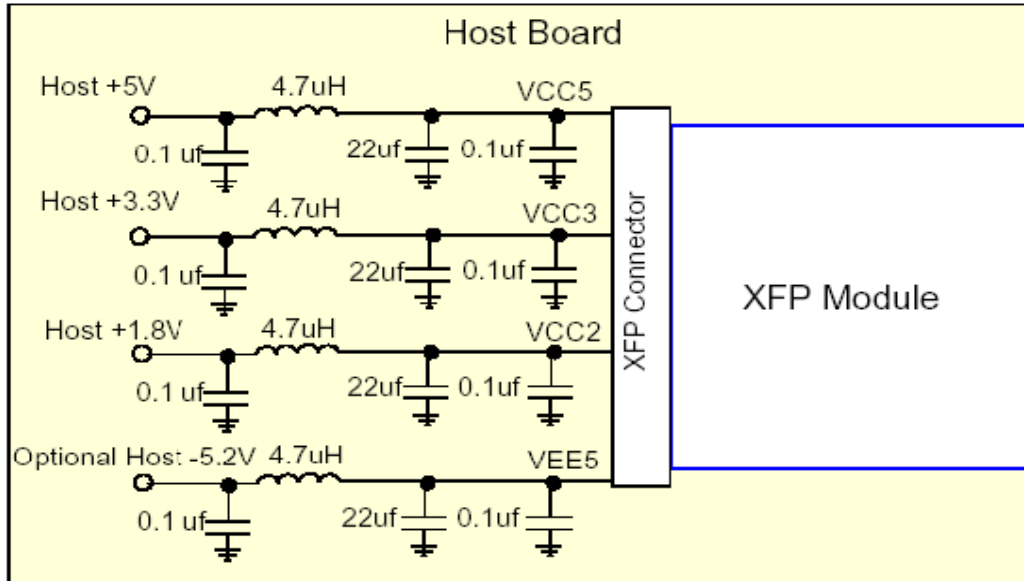

**Recommended Host Board Power Supply Circuit**

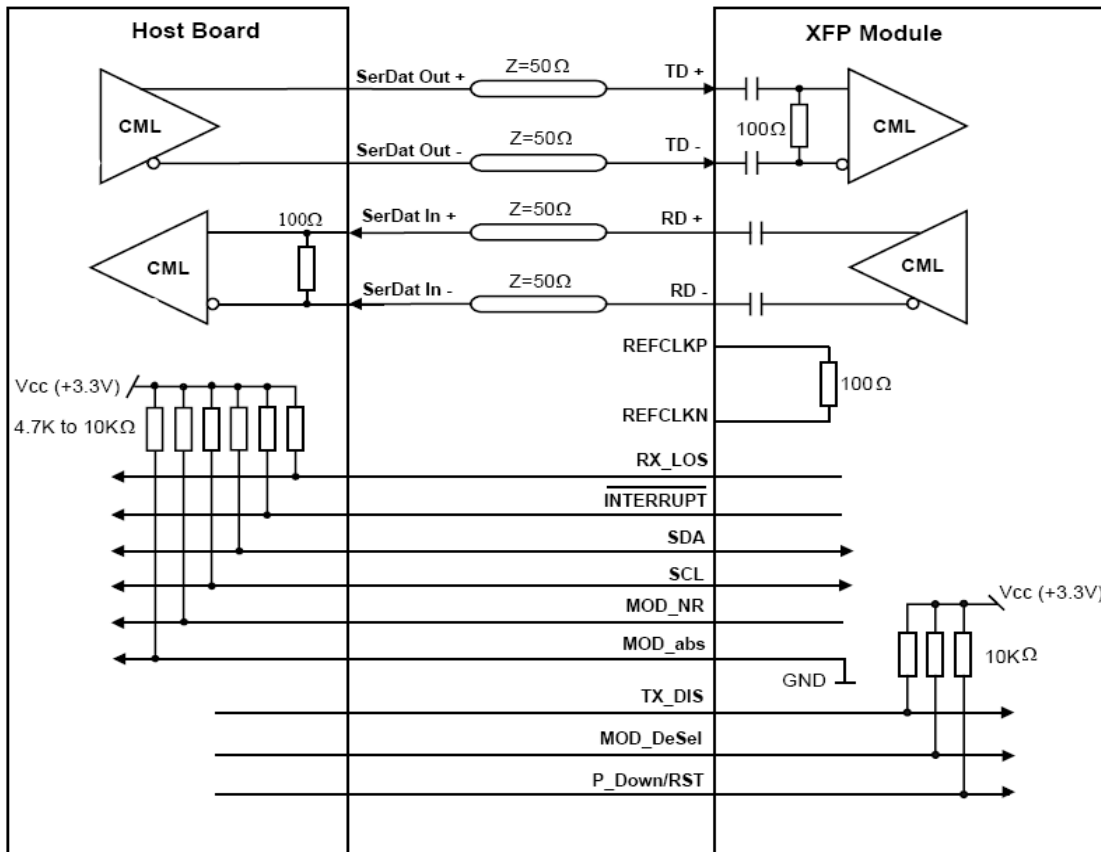

**Recommended High-speed Interface Circuit**

All rights reserved, including intellectual property rights. Technical data subject to modifications and delivery subject to availability. Any liability that the data and illustrations are complete, actual or correct is excluded. Designations may be trademarks and/or copyrights of the respective manufacturer, the use of which by third parties for their own purposes may infringe the rights of such owner.

## Data Sheet

# 10Gb CWDM XFP Transceiver, 80km Hot Pluggable, Duplex LC, CWDM EML-LD, APD Receiver, SM PXF-1C71SF-XX

Issue: November 2010



### Mechanical Dimensions:

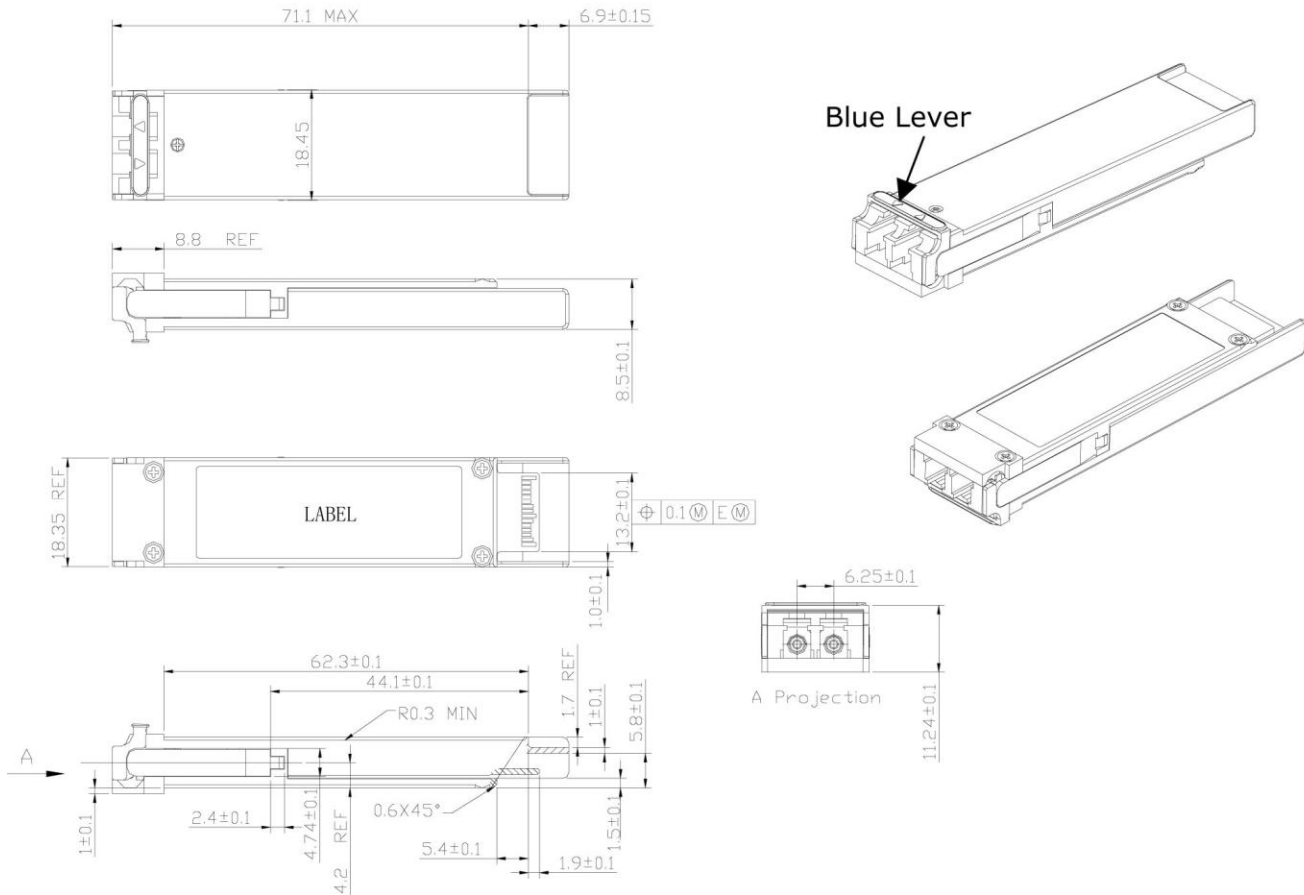

### Order Information:

In the Part No. of PXFP-1C71SF-XX, XX stands for wavelength, such as:

**27:** for 1270nm, **29:** for 1290nm, **31:** for 1310nm, **33:** for 1330nm, **35:** for 1350nm,  
**37:** for 1370nm, **39:** for 1390nm, **41:** for 1410nm, **43:** for 1430nm, **45:** for 1450nm,  
**47:** for 1470nm, **49:** for 1490nm, **51:** for 1510nm, **53:** for 1530nm, **55:** for 1550nm,  
**57:** for 1570nm, **59:** for 1590nm, **61:** for 1610nm.

All rights reserved, including intellectual property rights. Technical data subject to modifications and delivery subject to availability. Any liability that the data and illustrations are complete, actual or correct is excluded. Designations may be trademarks and/or copyrights of the respective manufacturer, the use of which by third parties for their own purposes may infringe the rights of such owner.